

1/4 VGA Cholesteric Display Modules and Controller Assemblies

Display Module with Integrated Controller



Product Description

320 x 240 (1/4 VGA) Display Modules are for general purpose graphic and character display applications. All Kent Displays Cholesteric Liquid Crystal Display (ChLCD) products take advantage of the technology's unique "No Power" attribute without compromising superior optical performance even in direct sunlight.

The 320 x 240 Controller can be fully integrated onto the display driver module, or these displays are available without the controller logic for custom user applications.

Display modules with the integrated controller require a communication cable, CD-ROM, and DC power supply for operation.

Demonstration Kit



The 320 x 240 Demonstration Kit contains everything you need to quickly evaluate the features and capabilities of the 320 x 240 system.

Each demonstration kit contains a 320 x 240 display module with integrated controller (part # 01529701xxx), attached AA cell holder and batteries, communication cable, (part # 010123), and CD-ROM with user interface software & related documents (part # 03930).

Kent Displays, Inc.
343 Portage Boulevard
Kent, OH 44240, USA

Telephone: (330) 673-8784
Fax: (330) 673-4408
Sales: sales@kentdisplays.com
Website: www.kentdisplays.com

Product Features

Display Module:

- 320 Columns x 240 Rows
- 71 DPI (dots per inch)
- Approximate Overall Size: 6.10x4.35x0.3 Inches
- Available in Four Colors
- 5V Logic Interface
- Low Profile Modular Design
- Superior Brightness
- Excellent Optical Quality
- Viewing Cone Comparable to Paper
- Full or Partial Screen Update Capability
- Indefinite Image Memory ("No Power")

Controller:

- Font Generator & Graphic Image Capability
- Communication Options
 - RS-232 Interface
 - Local Serial Interface
- Automatic Sleep Mode
- LED Indicators to Support Operation & Control
- Input Voltage: 3 - 9 VDC
- Built-In Test Mode

Typical Applications

- Battery Powered Portable Devices
- Machine Interface Displays
- General Purpose Indoor or Outdoor Signage
- Instrumentation Displays
- Point of Sale Displays
- Fuel Pump Displays

Ordering Information:

| Display Module* – RS232 | |
|-------------------------|------------------------------------|
| Part # | Description |
| 01529701166 | Module, 320x240 Yellow/Black |
| 01529701167 | Module, 320x240 White/Blue |
| 01529701168 | Module, 320x240 Yellow-Green/Black |
| 01529701169 | Module, 320x240 Green/Black |

| Demonstration Kit | |
|-------------------|--------------------------------------|
| Part # | Description |
| 09002401166 | Demo Kit, 320x240 Yellow/Black |
| 09002401167 | Demo Kit, 320x240 White/Blue |
| 09002401168 | Demo Kit, 320x240 Yellow-Green/Black |
| 09002401169 | Demo Kit, 320x240 Green/Black |

| Display Module* – Local Serial | |
|--------------------------------|---|
| Part # | Description |
| 01529702166 | Module, 320x240 Yellow/Black, TTL |
| 01529702167 | Module, 320x240 White/Blue, TTL |
| 01529702168 | Module, 320x240 Yellow-Green/Black, TTL |
| 01529702169 | Module, 320x240 Green/Black, TTL |

| Related Items | |
|---------------|---------------------|
| Part # | Description |
| 01012301 | Communication Cable |
| 03930 | Software CD |

*All 320 x 240 display modules (01529701xxx & 01529702xxx) require a serial communication cable and DC power supply for operation.

Contact Kent Displays at sales@kentdisplays.com for complete sign assemblies, custom configurations, pricing, and additional information.

Display Modules and Controllers

| General Specifications | |
|--|--|
| Parameter | Description |
| Display Type | Cholesteric Reflective LCD |
| Format | 320 columns x 240 rows |
| Resolution | 71.4 dots per inch, or 0.355 mm between pixel center-lines |
| Image Area | 4.5 in x 3.4 in (113.8 mm x 85.3 mm) [142.2 mm or 5.6 in diagonal] |
| Display Module Weight | 5.3 oz (150 grams) |
| Operating Temperature Range | 0°C to +60°C (custom operating temperatures available) |
| Storage Temperature Range | -40°C to +100°C |
| Full Image Update Rate | 1.7 sec (@ 23°C, refer to graph on page 7 for more details) |
| Maximum Number of Display Modules per Controller | 1 |
| Sleep Mode Activated After | 20 sec |

| 320x240 Display Module Power Requirements ¹ | | | |
|--|---------|---------|---------|
| Parameter | Minimum | Typical | Maximum |
| Power Source Voltage Range (V_{DD}) – (RS-232 & Local Serial variations) | 3.6 VDC | 6.0 VDC | 9.0 VDC |
| High Level Logic Input Voltage (V_{IH}) | 3.0 VDC | - | - |
| Low Level Logic Input Voltage (V_{IL}) | - | - | 0.8 VDC |
| Average Operating Power (while driving image) | - | 215 mW | - |

| Controller Power Requirements ¹ | | | |
|---|---------|-------------|---------|
| Parameter | Minimum | Typical | Maximum |
| Power Source Voltage (V_{DD}) | 3.6 VDC | 6.0 VDC | 9.0 VDC |
| Average "Wake-up" mode power consumption when updating a display module | - | 127 mW | - |
| Average "Idle" mode power consumption | - | 43 mW | - |
| "Sleep Mode" power consumption display module & controller | - | < 6 μ W | - |

| Controller Communication Interface Information | |
|--|---|
| Parameter | Description |
| Serial communication format | RS-232: Asynchronous, full duplex, 8 data bits, 1 stop bit, no parity. |
| Baud rate | 38.4 kbps |
| Protocol format | Kent Displays character/graphics serial protocol. (Refer to Data Sheet 25016 for details). |
| Mating communication plug | 2mm pitched 3-conductor plug, Hirose P/N DF3-3S-2C w/ DFS-2428SC crimped contacts, or equivalent. |

*Specifications are subject to change without prior notice.

¹ Values given assume 25 °C Temp.

320x240 Display Module Update Cycle Power @25°C

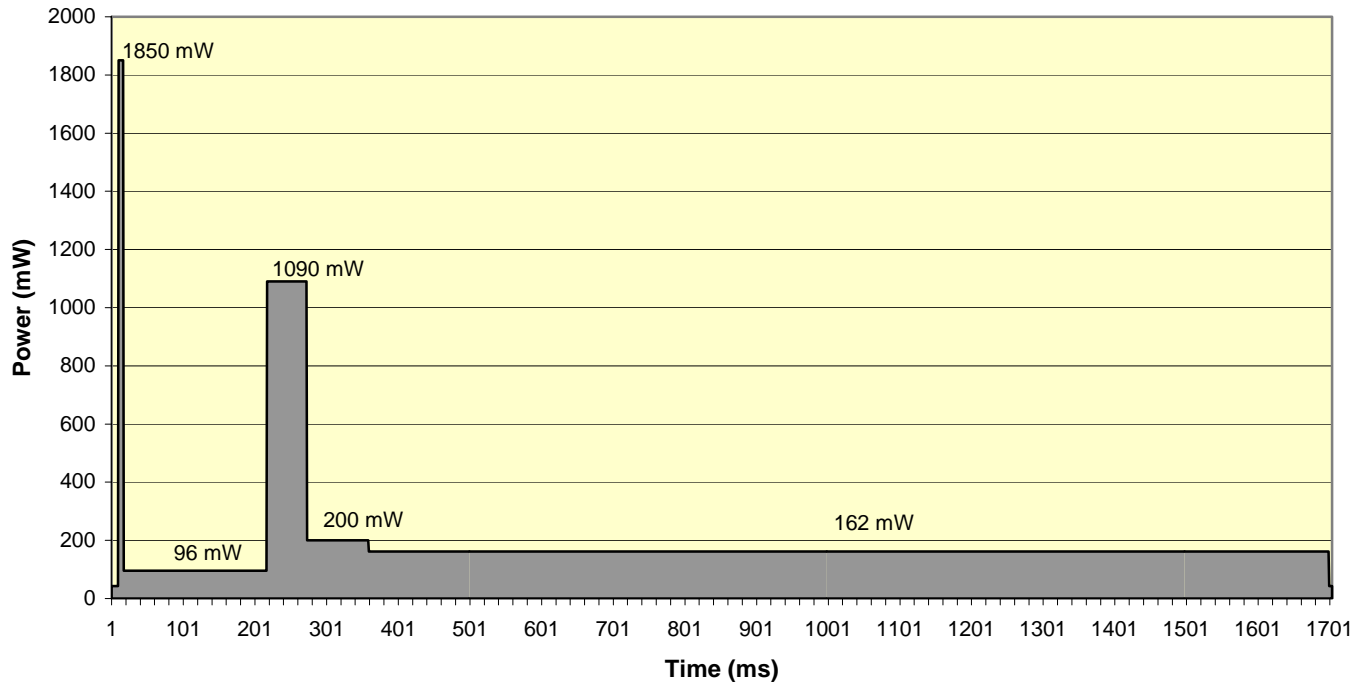

320x240 Display Module Update Cycle Power @60°C

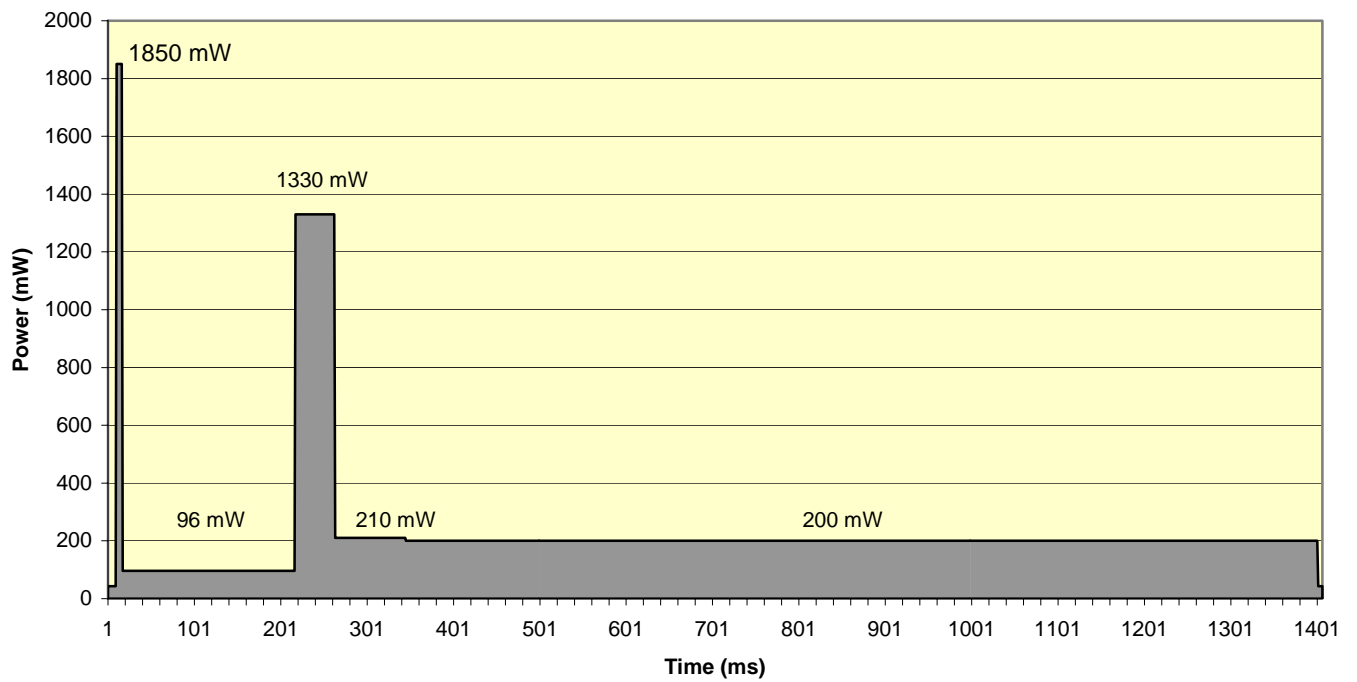

*Note: Display controller consumes 43mW when the display is not updating (idle mode).

Controller:

| Power Supply Header: J1 | | |
|--------------------------------|----------------------------|-----------------------------|
| Pin # | Symbol | Description |
| 1 | + Power (V _{DD}) | Positive power termination. |
| 2 | - Power (GND-Return) | Negative power termination. |

| Communication Header Interface: J5 | | |
|---|---------|--|
| Pin # | Symbol | Description |
| 1 | RX_DATA | Module receive- data input termination (RS-232).. |
| 2 | Ground | Ground termination point (RS-232 use only). |
| 3 | TX_DATA | Module transmit- data output termination (RS-232). |

| Local on Board Control Descriptions | |
|--|---|
| Symbol | Description |
| "RESET" | Controller reset button. |
| "TEST" | Controller diagnostic button input for onboard control. |
| "WAKE-UP" | Module local wakeup button input. |
| D8, "LED" | LED diagnostic output controlled for onboard feedback. |

Application Block Diagrams

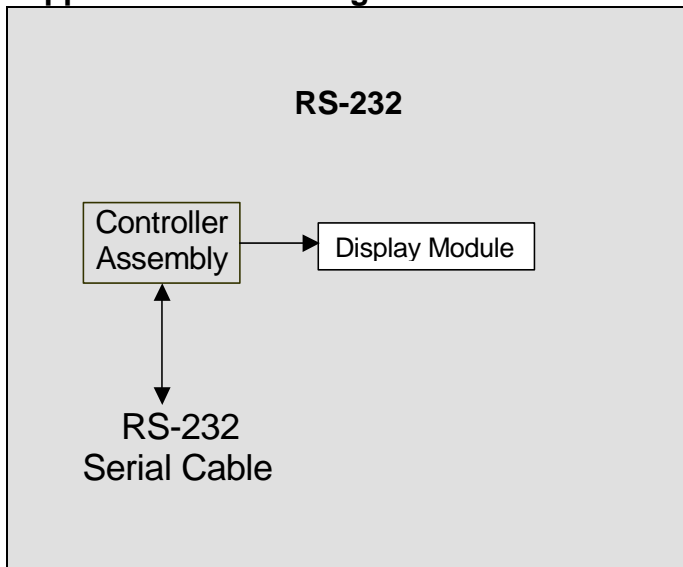

Mechanical Dimensions:

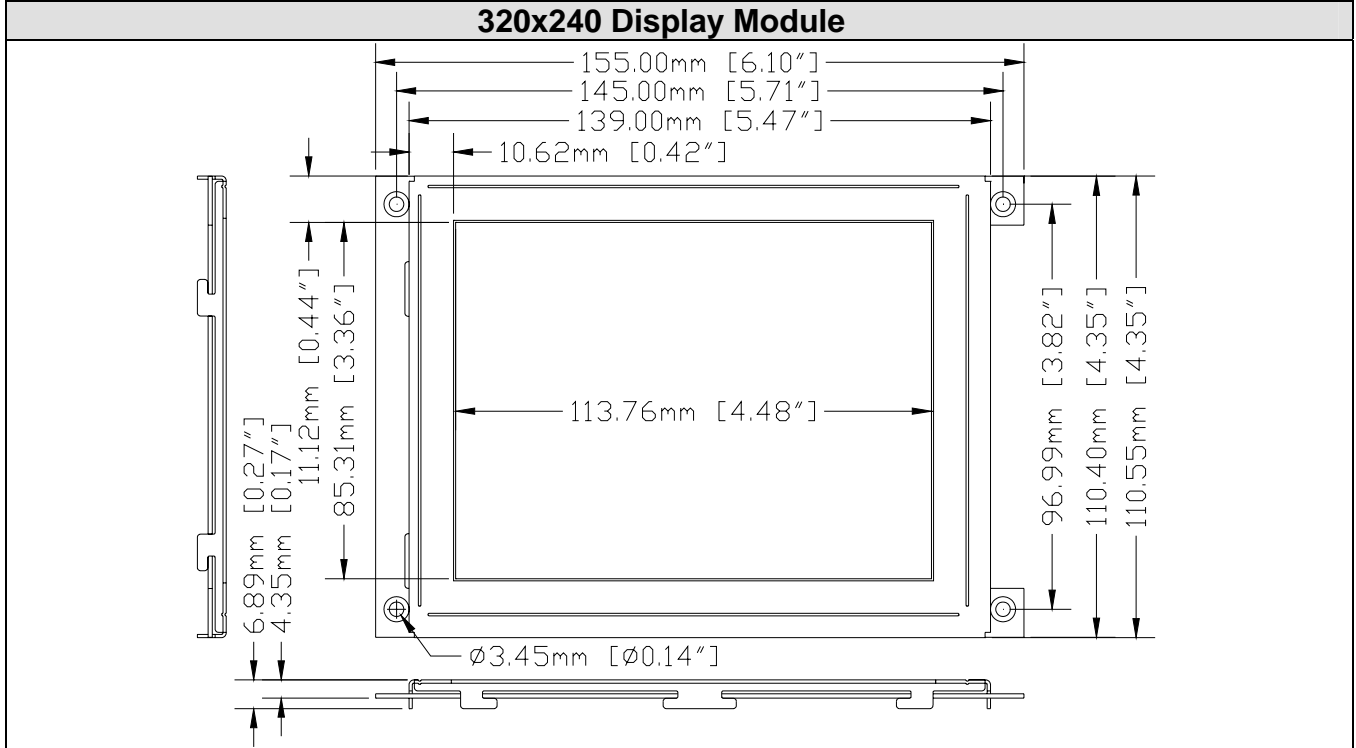
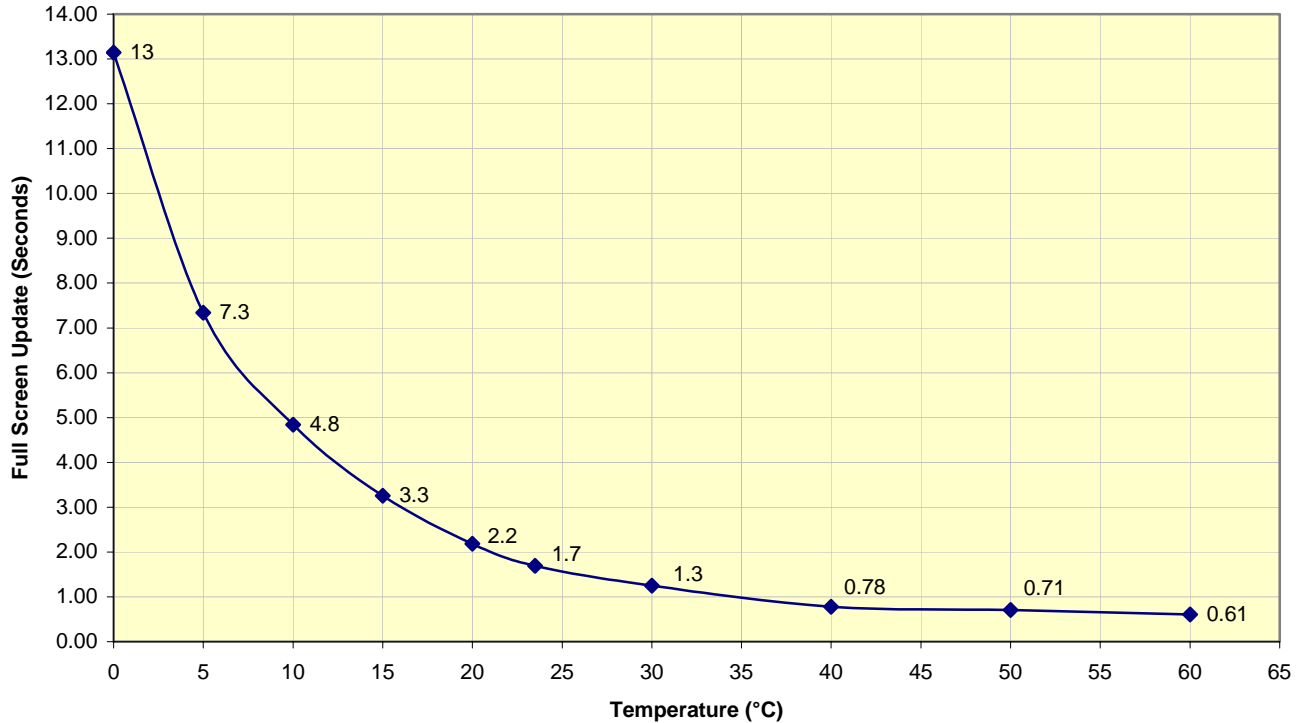

Image Update Information

320 x 240 (1/4 VGA) Display Module Total Update Time



The chart above illustrates measured full screen update durations with respect to temperature for 320 x 240 display module. The update duration is approximately 1.7 seconds at room temperature.

FRONT COVER MATERIAL SELECTION:

The following front cover requirements are necessary to insure image quality during the life of the 320x240 display module:

1. Cholesteric Liquid Crystal materials require protection from UV light. A UV blocking material with a minimum 98% cutoff at 380nm and lower spectral components is required.
2. The finished product design should incorporate a transparent cover such as acrylic, polycarbonate, etc., to protect the viewing area of the display. Place the protective cover as close to the display module as possible. The protective cover should be of sufficient thickness to resist flexing, or if flexed should not touch the surface of the display. Acrylite® OP-3 P-99 matte finish and Acrylite® OP-3 material without matte finish are examples of a recommended protective cover material.

Adding an anti-glare and/or anti-reflective surface film or finish to the viewing side of the protective cover may improve the optical performance in certain display applications and lighting conditions.

Optical Characteristics for Standard Color Configurations

The graphs to the left outline the spectral reflectance characteristics for a given display pixel when switched to either of the two possible stable states: reflective planar or transparent focal conic. The top line in each chart outlines the reflective characteristic of the planar state. The bottom line outlines the reflective characteristic of the transparent focal conic state. Graphs for the 4 standard color combinations are illustrated.

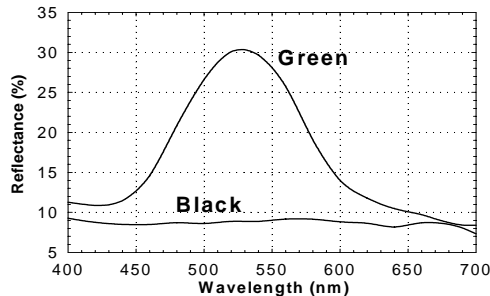
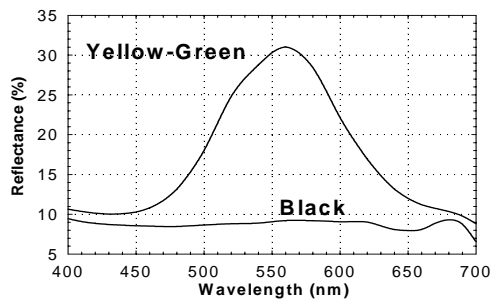
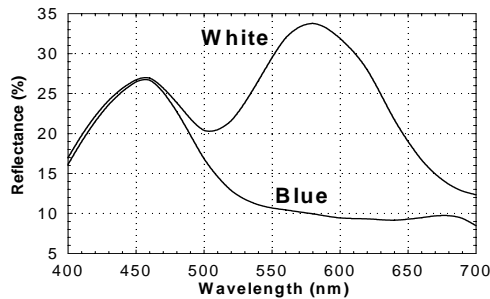
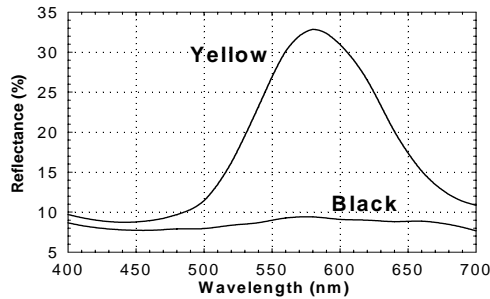

The above reflectance curves are from a single pixel. Actual reflectance will vary depending on display resolution, aperture ratio, and other factors.

Contrast Ratio Polar Representation

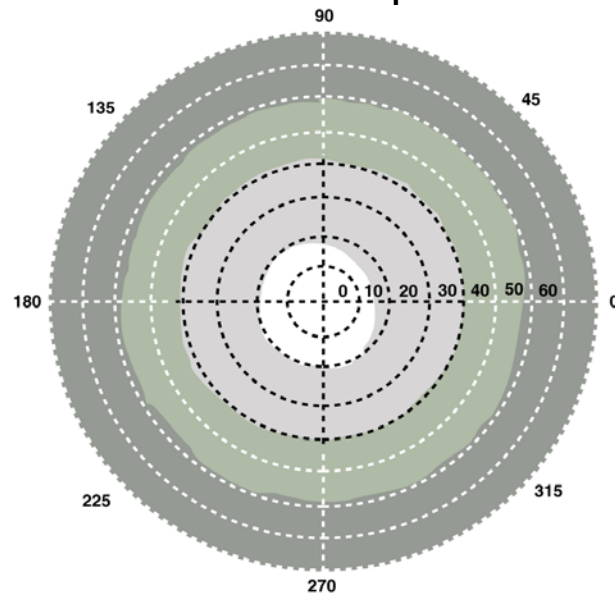

As illustrated in the polar graph above, all Kent Displays' ChLCD products have a 360-degree viewing cone. When measured normal to the plane of the display, the monochromatic contrast ratio is as high as 25:1 with a peak reflectivity approaching 35% of the incident light. The contrast ratio reduces as the viewing angle approaches the plane of the display but is still excellent at 11:1. Since no polarizers are used, display contrast reduces uniformly in all azimuthal directions when the viewing angle is increased.

Products and technologies of Kent Displays, Inc. are protected by the US Patents: 5,493,430, 5,570,216, 5,636,044, 5,644,330, 5,251,048, 5,384,067, 5,437,811, 5,453,863, 5,668,614, 5,691,796, 5,695,682, 5,748,277, 5,766,694, 5,847,798 and numerous other patent applications by Kent Display Systems, Inc., Kent Displays, Inc. and Kent State University pending in the U.S. and in foreign patent filings include: PCT, Canada, China, Europe, Israel, Japan, Korea, and Taiwan among others.